

Paasche Talon TG#2L Airbrush Gravity Feed Dual Action

TG#2L

Illustrated Parts Listing

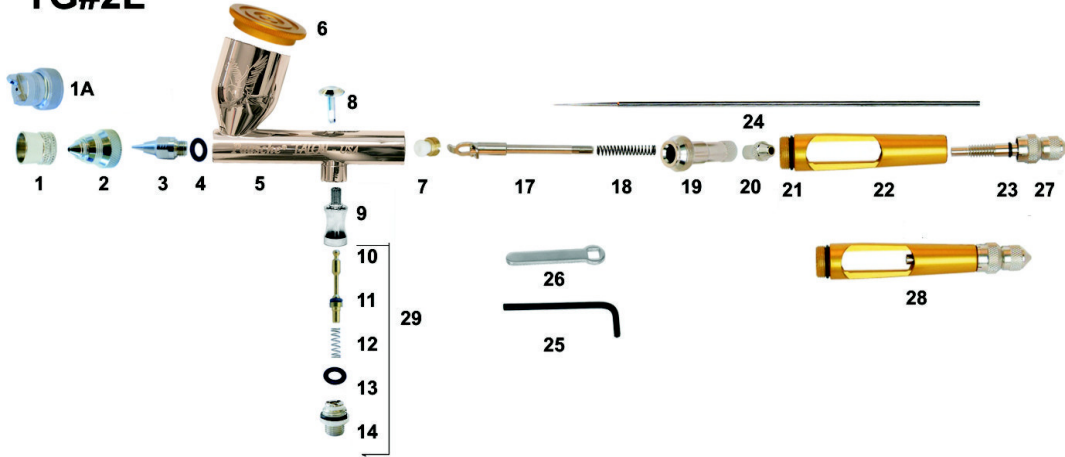

Item #	Part No.	Description
1	XI-41	Needle Protecting Cap
2	TA-2	Air Cap 2 ((0.38mm)
3	TT-2	Tip #2 (038mm)
4	MIL-12	O-ring
5	TG-30	TG Shell Assemble
6	TG-4	Cup Cover
7	TAL-8	Packing Assembly PTFE
8	TAL-37	Trigger
9	TAL-14	Valve Casing
10	TAL-36	Valve Plunger w/O-ring
11	A-53	O-ring (Pk of 6)
12	A-22	Spring
13	TAL-22	O-ring (Pk of 6)
14	TAL-15	Valve Adapter w/O-ring
17	TAL-18	Rocker Assembly
18	MIL-11	Needle Spring
19	TAL-17	Spring Housing
20	TAL-19	Needle Lock Nut
21	MIL-12	O-Ring
22	TAL-20	Handle (N/A use TAL-34)
23	3A-4	O-ring (Pk of 6)
24	TN-2	Needle #2 (0.38mm)
27	TAL-33	Needle Stop
28	TAL-34	Handle w/Needle Stop
29	TAL-32	Air Valve Assemble (Parts TAL-36, A53, A22, TAL-14, TAL-15)
Optional		
25	TAL-35	Allen Wrench
26	TAL-28	Wrench
N/S	T-227-2	Tip, Head and Needle #2 (0.38 mm)
N/S	TG-10RK	Repair Kit (TAL-37, TAL-8, TAL-26, TAL-18, TAL-32, MIL-11, TAL-17, TAL-19 and TAL-23)
Also Available		
1A	TAF-3	Fan Cap for (0.66 mm) Use with TT3, TN3
1A	TAF-4	Fan Cap for (1.00 mm) Use with TT4, TN4
2	TA-1	Air Cap #1 (0.25mm)
2	TA-3	Air Cap #3 (0.66mm)
2	TA-4	Air Cap #4 (1.00mm)

Item #	Part No.	Description
3	TT-0	Tip #0 (0.20 mm)
3	TT-1	Tip #1 (0.25 mm)
3	TT-3	Tip #3 (0.66 mm)
3	TT-4	Tip #4 (1.00 mm)
24	TN-0	Needle #0 (0.20 mm)
24	TN-1	Needle #1 (0.25 mm)
24	TN-3	Needle #3 (0.66 mm)
24	TN-4	Needle #4 (1.00mm)
N/S	T-227-0	Tip, Head and Needle #0 (0.20 mm)
N/S	T-227-1	Tip, Head and Needle #1 (0.25 mm)
N/S	T-227-3	Tip, Head and Needle #3 (0.66 mm)
N/S	T-227-4	Tip, Head and Needle #4 (1.00 mm)
To Change TG#2 to TG#0 change the following Parts for Optimum Performance:		
2	TA-1	Air Cap #1 (0.25 mm)
3	TT-0	Tip #0 (0.2 mm)
24	TN#0	Needle #0 (0.2 mm) OR
N/S	T-227-0	Air Cap, Tip and Needle #0 (0.20 mm)
To Change TG#2 to TG#1 change the following Parts for Optimum Performance:		
2	TA-1	Air Cap #1 (0.25 mm)
3	TT-1	Tip #0 (0.25 mm)
24	TN#1	Needle #0 (0.25 mm) OR
N/S	T-227-1	Air Cap, Tip and Needle #1 (0.25 mm)
To Change TG#2 to TG#3 change the following Parts for Optimum Performance:		
2	TA-3	Air Cap #3 (0.66 mm)
3	TT-3	Tip #3 (0.66
24	TN#3	Needle #3 (0.66 mm) OR
N/S	T-227-3	Air Cap, Tip and Needle #3 (0.66 mm)
To Change TG#2 to TG#4 change the following Parts for Optimum Performance:		
2	TA-4	Air Cap #4 (1.00 mm)
3	TT-4	Tip #4 (1.00 mm)
24	TN#4	Needle #4 (1.00 mm) OR
N/S	T-227-4	Air Cap, Tip and Needle #4 (1.00 mm)

See next Page for schematic

TG

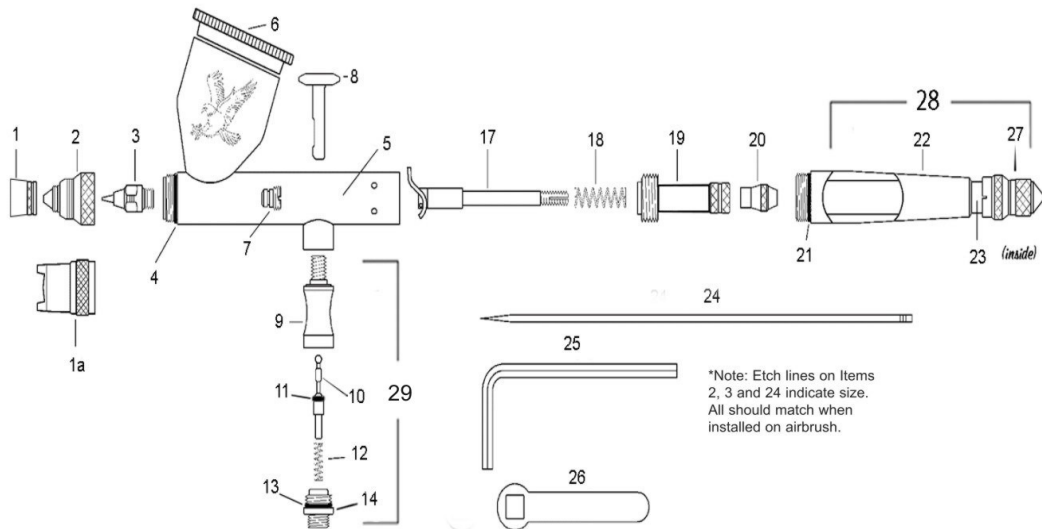

- | | | | | |
|-----|-----------------|-----------------------------------|--|--|
| 1. | XI-41 | Cap | | |
| 1a. | TAF-3 | Fan Aircap for .66mm head | | |
| 2. | TA-1,2,3 or 4 | Aircap (TA-1 used w/ 0 & 1 heads) | | |
| 3. | TT-0,1,2,3 or 4 | Tip | | |
| 4. | MIL-12 | "O" Ring | | |
| 5. | TG-30 | Shell Assembly | | |
| 6. | TG-4 | Cup Cover | | |
| 7. | TAL-8 | Packing Assembly PTFE | | |
| 8. | TAL-37 | Trigger | | |
| 9. | TAL-14 | Valve Casing | | |
| 10. | TAL-36 | Valve Plunger (Includes O-ring) | | |
| 11. | A-53 | O-ring Pack of (6) O-rings | | |
| 12. | A-22 | Spring | | |
| 13. | TAL-22 | O-ring (Pack of (6) O-rings) | | |
| 14. | TAL-15 | Valve Adapter (with O-ring) | | |
| 17. | TAL-18 | Rocker Assembly | | |
| 18. | MIL-11 | Needle Spring | | |
| 19. | TAL-17 | Spring Housing | | |
| 20. | TAL-19 | Needle Lock Nut | | |
| 21. | MIL-12 | "O" Ring | | |
| 22. | TAL-20 | Handle | | |
| 23. | 3A-4 | "O" Ring | | |
| 24. | TN-0,1,2,3 or 4 | Needle | | |
| 25. | TAL-35 | Allen Wrench | | |
| 26. | TAL-28 | Wrench | | |
| 27. | TAL-33 | Needle Stop | | |
| 28. | TAL-34 | Handle w/ Needle Stop | | |
-
- | | |
|--|--|
| <u>Optional Parts:</u> | |
| <u>Head components:</u> | |
| TAF-3 | Fan Aircap for .66mm (use with TT-3 & TN-3) |
| TT-1, 3 or 4 | Tip (.25, .66 or 1mm) |
| TN-1, 3 or 4 | Needle (.25, .66 or 1mm) |
| TA-1, 3 or 4 | Aircap (.25, .66 or 1mm) |
| <u>Complete Head</u> | |
| T-227-1 | Size 1 Head |
| (.25mm) | |
| T-227-2 | Size 2 Head (.38mm) |
| T-227-3 | Size 3 Head (.66mm) |
| T-227-4 | Size 4 Head (1mm) |
| <u>Air hoses with Coupligs Installed</u> | |
| A-1/8-size | Braided Airhose (6', 8', 10', 15', 20', 25' & 50') |
| 3A-4 | Airbrush side "O" ring |
| HPB-1/8-10 | 10' Black Plastic Airhose |

WARNING: Spray materials may be harmful if inhaled or allowed to come into contact with the skin or eyes. Consult the product label and material safety data sheet supplied for the spray material. Follow all safety precautions. **CAUTION:** Well Ventilated Area Required to remove fumes, dust or overspray. **Maximum Air Pressure 75 P.S.I.**

Paasche Airbrush Co. 9511 58th Place Kenosha, WI. 53144 Phone:773/867-9191 Email:info@paascheairbrush.com

Available from: *Dixie Art Airbrush* • www.dixieart.com • 800.783.2612 / 504.466.6556