

Paasche®

HSSB-30-16 Hobby-Shop Spray Booth

OPERATING INSTRUCTIONS AND REPLACEMENT PARTS Twin Exhaust Fans - each using (235 CFM, 115 Volts, 60 Cycle, .43 AMPS)

ASSEMBLY INSTRUCTIONS:

1. Assemble booth per instructions on the back of this sheet.
2. Place spray booth on a sturdy stable surface larger than its base (30" x 20") and capable of supporting 45lbs. or more.
3. The plenum chamber screen is factory installed from the front of the spray booth (Illustration C).
4. AG-8 paint filter is factory installed into the plenum chamber so they are secured by the outer perimeter of the inlet to the plenum chamber (Illustration A).

CAUTIONS:

1. Do not use this equipment in explosive atmospheres or with flammable materials.
2. Plug the unit into 3 hole properly grounded outlet. Always un-plug the unit before assembly or disassembly of components or changing filters.
3. Do not operate the unit near running water or a wet surface. Avoid any type of exposure of the motor to direct moisture.
4. Wiping or cleaning rags and other flammable waste materials must not be used near the motor when operating. Waste materials must be disposed of in a proper fashion.
5. Do not remove the Fan Outlet Grill. The fan blade is sharp and can cause serious injury if contacted while running. Use Fan Outlet Adapter for exhausting to the outside.
6. This unit is intended to remove larger particles from the air when painting small objects such as models and pottery. It will not remove all hazardous material from the air so caution should be taken when spraying materials that have strong vapors or harmful chemicals. **Wear protective paint and vapor mask and vent the unit to the outside atmosphere using 4" dryer duct hose from your local hardware store. Change the booth filter frequently.**

WARNING: Spray materials may be harmful if inhaled or allowed to come into contact with the skin or eyes. Consult the product label and Material Safety Data Sheet supplied for the spray material. Follow all safety precautions. Use HSSB to create a Well Ventilated Area to remove fumes, dust or overspray. Exhaust to the outside. Change filters frequently and dispose of in a safe manner. **Fan Outlet Grills Must Be Installed At All Times When Not Using Dryer Hose Adapter. Before spraying make sure air is blowing out of booth as shown below.**

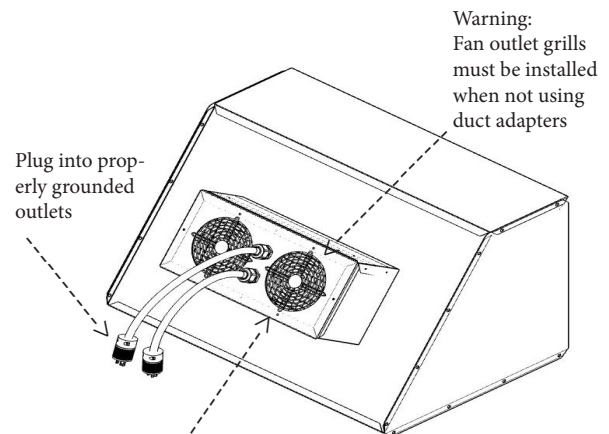
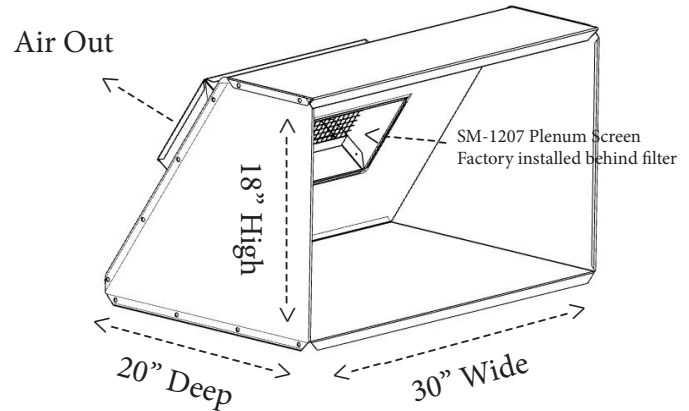

4" dryer hose adapter for exhausting to the outside.

Secure each adapter using two horizontal screw holes on blower assembly.

Vertical screw holes hold the Fan - do not remove.

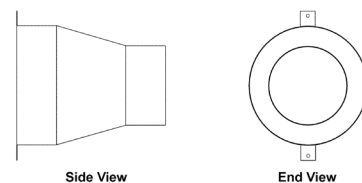

Paasche Airbrush Company
9511 58th Place, Kenosha, WI 53144
Phone: 773-867-9191
Website: www.paascheairbrush.com
E-Mail: info@paascheairbrush.com

Available from:
Dixie Airbrush
www.dixieart.com
504.236.2163

CAUTION! EDGES MAY BE SHARP.
 MAKE SURE FAN EXHAUST IS
 BLOWING OUT OF BOOTH BEFORE
 SPRAYING.

BOOTH ASSEMBLY INSTRUCTIONS

A PHILLIPS SCREW DRIVER IS REQUIRED TO TIGHTEN SCREWS.

ALL 20 SCREW HEADS FACE OUTSIDE OF BOOTH.

- 1) APPLY A ROW OF SPONGE RUBBER TAPE ALONG FLANGE OF TOP PANEL AND BOTTOM OF BACK PANEL (BACK VIEW)
 - 2) ASSEMBLE SIDE PANELS TO FLOOR PANEL (FRONT VIEW)
 - 3) INSERT BACK PANEL BETWEEN SIDE PANELS (RIGHT SIDE DETAIL)
 - 4) INSTALL TOP PANEL (RIGHT SIDE DETAIL)
- * LOWER END OF TOP PANEL RESTS INSIDE OF BACK PANEL *

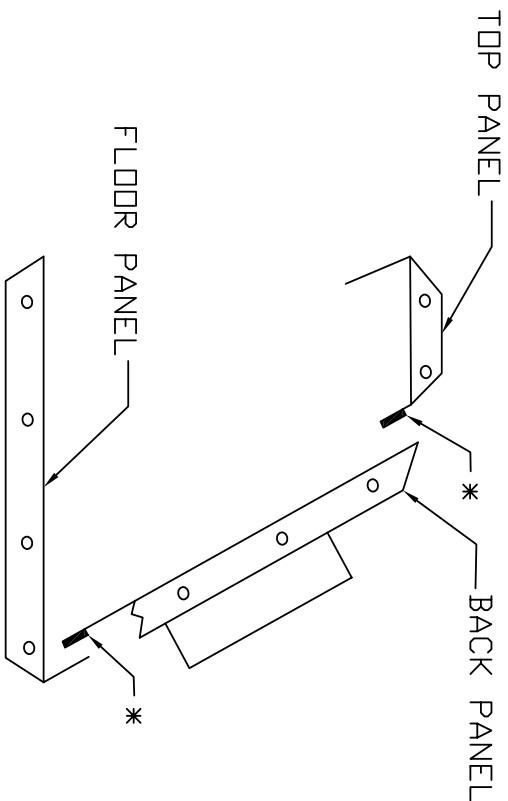

RIGHT SIDE DETAIL

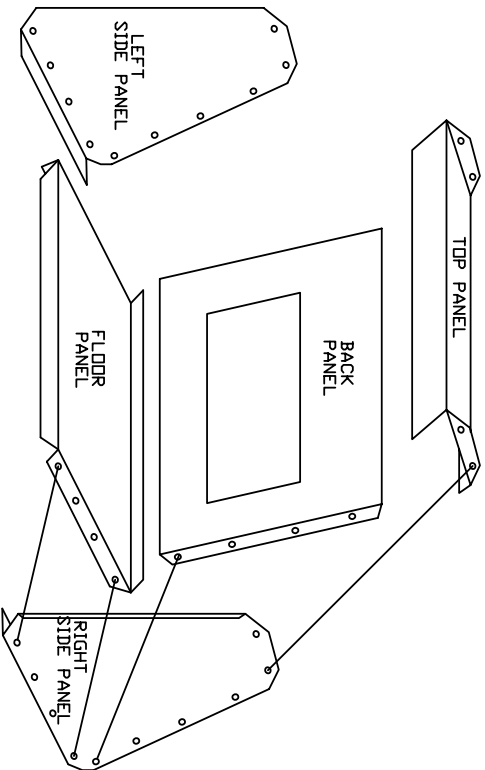

FRONT VIEW

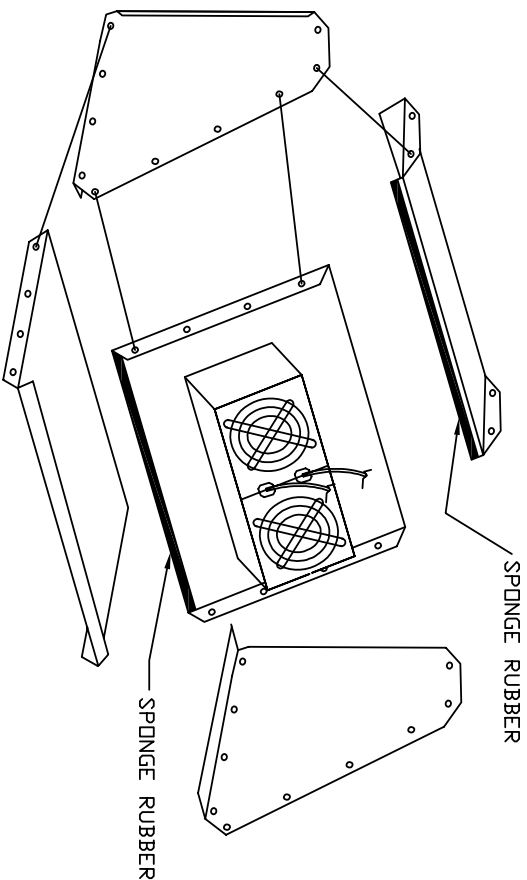

BACK VIEW